

TECHNISCHE DATEN



RAUPENBAGGER | JZ140 LC

Brutto-Motorleistung: 81 kW (109 PS) | Löffelinhalt: 0,35–0,89 m³ | Betriebsgewicht: 15.084–16.826 kg



STATISCHE ABMESSUNGEN

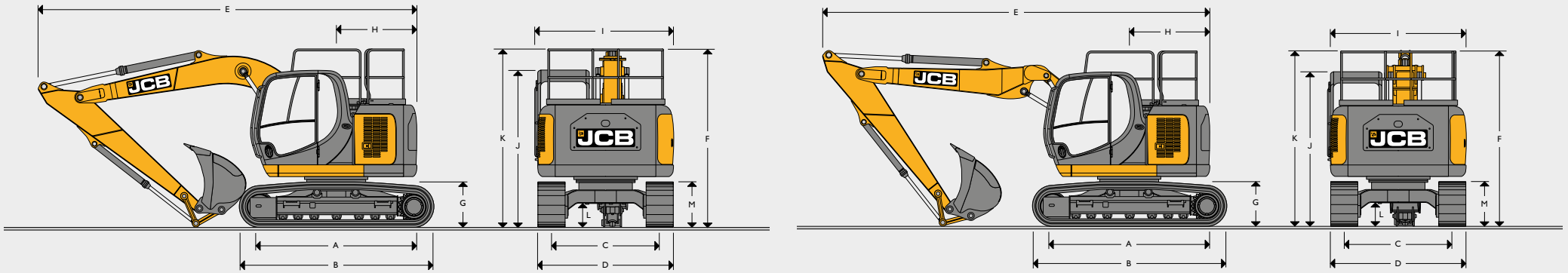

STATISCHE ABMESSUNGEN

Abmessungen in mm		Monoausleger					Verstellausleger						
		LC					LC						
A	Kettenaufstandslänge	2.865					2.865						
B	Laufwerksgesamtlänge	3.590					3.590						
C	Spurweite	1.990					1.990						
D	Laufwerksbreite (500-mm-Bodenplatten)	2.490					2.490						
D	Laufwerksbreite (600-mm-Bodenplatten)	2.590					2.590						
D	Laufwerksbreite (700-mm-Bodenplatten)	2.690					2.690						
D	Laufwerksbreite (850-mm-Bodenplatten)	2.840					2.840						
Auslegeroptionen		Monoausleger 4,7 m					Verstellausleger 5,0 m						
Löffelstiellänge		2,5 m	2,7 m	3,0 m	2,5 m	2,7 m	3,0 m	2,5 m	2,7 m	3,0 m	2,5 m	2,7 m	3,0 m
E	Transportlänge	7.331	7.275	7.284	7.331	7.275	7.284	7.591	7.522	7.440	7.591	7.522	7.440
F	Transporthöhe	3.227	3.300	3.318	3.337	3.410	3.428	3.227	3.227	3.233	3.337	3.337	3.343
G	Bodenfreiheit Kontergewicht		916				1.026			916			1.026
H	Heckschwenkradius		1.485				1.485			1.485			1.485
I	Oberwagenbreite		2.500				2.500			2.500			2.500
J	Höhe über Kabine		2.842				2.952			2.842			2.952
K	Höhe über Haltegriff		3.227				3.337			3.227			3.337
L	Bodenfreiheit		434				440			434			440
M	Kettenhöhe		820				832			820			832

MOTOR	
Modell	JCB Dieselmax 448 TCA, EU-Stufe V
Typ	Wassergekühlter 4-Takt-, 4-Zylinder-Dieselmotoren mit Common-Rail-Direkteinspritzung, Turbolader mit variabler Geometrie und Ladeluftkühlung
Nennleistung (netto)	81 kW (109 PS) bei 2.200 U/min (ISO 14396)
Hubraum	4,765 l
Luftfilterung	Trockenelement mit sekundärem Sicherheitselement und Warnanzeige in der Kabine
Anlasser	24 Volt
Batterien	2 x 12 Volt
Lichtmaschine	24 Volt, 100 Ampere

SCHWENKSYSTEM	
Schwenkmotor	Axialkolbentyp
Schwenkbremse	Hydraulische Bremse sowie automatisch wirkende Federspeicher-Scheibenfeststellbremse
Schwenkmoment	36,1 kNm
Schwenkgeschwindigkeit	13,1 U/min
Schwenkgetriebe	Großer Durchmesser, innenverzahnt, vollständig versiegelt, Schmierung mit Schmierfettbad.

FAHRANTRIEB	
Typ	Voll hydrostatisches Zweiganggetriebe mit Automatikschaltung
Fahrmotoren	Verstellbarer Axialkolbenmotor mit Schrägachse, geschützt im Laufwerksrahmen
Endantrieb	Planetenuntersetzung, angeschraubte Kettenräder
Betriebsbremse	Hydraulisches Ausgleichsventil
Feststellbremse	Scheibentyp, federbetätigt, automatische Hydraulikfreigabe
Steigfähigkeit	70 % (35°) kontinuierlich
Fahrgeschwindigkeit	LC
	Hoch – 5,12 km/h
	Niedrig – 3,00 km/h
Schubkraft	120,5 kNm

FÜLLMENGEN	
	Liter
Kraftstofftank	193,7 l
Motorkühlmittel	23,6
Motoröl	14
Schwenkuntersetzungsgetriebe	2,2
Kettenuntersetzungsgetriebe (jede Seite)	3,5
Hydrauliksystem	160
Hydrauliktank	67
DEF-Behälter	18,5

LAUFWERK				
Laufwerkoptionen	LC – Langes Laufwerk			
Bauweise	Vollverschweißter Rahmen in X-Bauweise mit abgeschrägten Längsträgern sowie mit Reinigungsöffnungen unter den Stützrollen			
Schleppvorrichtung	Vorn und hinten			
Bodenplatten	500 mm	600 mm	700 mm	850 mm
LC	● X	●	●	●
Obere und untere Laufrollen	Wärmebehandelt, abgedichtet und geschmiert			
Ketteneinstellung	Fettzylinder			
Laufkettenrad	Abgedichtet und geschmiert, mit Federdämpfung			
Kettentyp	Abgedichtet und geschmiert			
Rollen und Bodenplatten (jede Seite)	LC			
Anz. Laufwerksführungen (optional)	2			
Anzahl untere Laufrollen	7			
Anzahl obere Laufrollen	2			
Anzahl Bodenplatten	44			

● = Dreifachsteg, **X** = Geogrip

HYDRAULIKSYSTEM

Offen zentriertes Hydrauliksystem mit Negativkontrolle und Doppelkolbenpumpen mit variablem Durchfluss für bedarfsgesteuerten Durchfluss

Pumpen

Hauptpumpen	2 variable Axialkolbenverstellpumpen
Max. Förderleistung	2 x 124 l/min
Servopumpe	Zahnradpumpe
Max. Förderleistung	20,5 l/min

Steuerventil

Serienmäßig kombiniertes Steuerventil mit vier und fünf Kreisen und zusätzlichem Betriebsventil

Einstellungen des Druckbegrenzungsventils

Ausleger/Löffelstiel/Löffel	314 bar
Mit Powerboost (Kraftverstärkung)	343 bar
Schwenkkreis	279 bar
Fahrkreis	343 bar
Vorsteuerung	40 bar

Filtersystem

Tank	150 Mikrometer, Ansaugsieb
Hauptrücklaufleitung	10 Mikrometer, Glasfaserelement
Vorsteuerleitung	10 µm, Papierelement
Rücklauf, hydraulischer Hammer	10 Mikrometer, verstärktes Mikrofaserselement

GEWICHTE UND BODENDRÜCKE

Gewichtsangaben inklusive: 383-kg-Löffel, Fahrer, voller Kraftstofftank und 2,5-m-Löffelstiel

		500-mm-Bodenplatte	600-mm-Bodenplatte	700-mm-Bodenplatte	850-mm-Bodenplatte
LC-Monoausleger					
Maschinengewicht	kg	15.084	15.300	15.515	15.839
Bodendruck	kg/cm ²	0,48	0,41	0,35	0,30
LC-Verstellausleger					
Maschinengewicht	kg	15.607	15.823	16.038	16.361
Bodendruck	kg/cm ²	0,50	0,42	0,37	0,31
LC-Monoplanierschild					
Maschinengewicht	kg	15.856	16.079	16.304	-
Bodendruck	kg/cm ²	0,51	0,43	0,37	-
LC-Verstellausleger Planierschild					
Maschinengewicht	kg	16.378	16.602	16.826	-
Bodendruck	kg/cm ²	0,52	0,44	0,38	-

OPTIONALER SCHILD

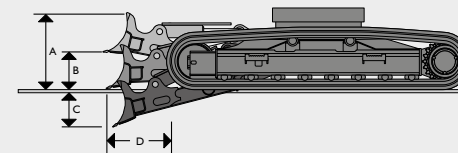

A	Schildhöhe	mm	447
B	Schildhub über Boden	mm	494
C	Einstechtiefe Schild	mm	508
D	Abstand Schild zu Kette	mm	412
	Planierschildbreite – 500-mm-Ketten	mm	2.510
	Planierbreite – 600-mm-Ketten	mm	2.610
	Planierbreite – 700-mm-Ketten	mm	2.710

Zusätzliches Maschinengewicht mit Schild

	500-mm-Ketten	kg	636
	600-mm-Ketten	kg	644
	700-mm-Ketten	kg	653

Kein Planierschild für 850 erhältlich.

LÖFFEL- UND ARM-KOMBINATION – MONOBLOCKAUSLEGER

Löffeloptionen		GP-Löffel						HD-Löffel						Löffelklasse		
Löffelbreite	mm	600	700	800	1.000	1.200	1.300	600	700	800	1.000	1.200	1.300	1.524	1.836	1.836
Löffelinhalt	m³	0,35	0,42	0,50	0,66	0,81	0,89	0,35	0,42	0,50	0,66	0,81	0,89	0,65	0,79	0,79
Löffelgewicht	kg	286	312	335	383	428	454	336	364	402	455	520	546	453	523	582
LC																
2,50-m-Schnellwechsler (ohne Schnellwechsler)		□ (□)	□ (□)	□ (□)	□ (□)	■ (□)	■ (■)	□ (□)	□ (□)	□ (□)	□ (□)	■ (□)	■ (■)	□ (□)	■ (□)	■ (□)
2,70-m-Schnellwechsler (ohne Schnellwechsler)		□ (□)	□ (□)	□ (□)	□ (□)	■ (□)	■ (■)	□ (□)	□ (□)	□ (□)	□ (□)	■ (■)	● (■)	□ (□)	■ (□)	■ (■)
3,0-m-Schnellwechsler (ohne Schnellwechsler)		□ (□)	□ (□)	□ (□)	□ (□)	■ (■)	● (■)	□ (□)	□ (□)	□ (□)	□ (□)	● (■)	● (●)	□ (□)	● (■)	● (■)
LC + Planierschild																
2,50-m-Schnellwechsler (ohne Schnellwechsler)		□ (□)	□ (□)	□ (□)	□ (□)	□ (□)	□ (□)	□ (□)	□ (□)	□ (□)	□ (□)	□ (□)	■ (□)	□ (□)	□ (□)	■ (□)
2,70-m-Schnellwechsler (ohne Schnellwechsler)		□ (□)	□ (□)	□ (□)	□ (□)	□ (□)	■ (■)	□ (□)	□ (□)	□ (□)	□ (□)	■ (□)	■ (■)	□ (□)	■ (□)	■ (□)
3,0-m-Schnellwechsler (ohne Schnellwechsler)		□ (□)	□ (□)	□ (□)	□ (□)	■ (□)	■ (■)	□ (□)	□ (□)	□ (□)	□ (□)	■ (■)	● (■)	□ (□)	■ (■)	■ (■)

LÖFFEL- UND ARM-KOMBINATION – VERSTELLAUSLEGER

Löffeloptionen		GP-Löffel						HD-Löffel						Löffelklasse		
Löffelbreite	mm	600	700	800	1.000	1.200	1.300	600	700	800	1.000	1.200	1.300	1.524	1.836	1.836
Löffelinhalt	m³	0,35	0,42	0,50	0,66	0,81	0,89	0,35	0,42	0,50	0,66	0,81	0,89	0,65	0,79	0,79
Löffelgewicht	kg	286	312	335	383	428	454	336	364	402	455	520	546	453	523	582
LC																
2,50-m-Schnellwechsler (ohne Schnellwechsler)		□ (□)	□ (□)	□ (□)	□ (□)	■ (■)	● (■)	□ (□)	□ (□)	□ (□)	■ (□)	● (■)	● (●)	■ (□)	● (■)	● (■)
2,70-m-Schnellwechsler (ohne Schnellwechsler)		□ (□)	□ (□)	□ (□)	■ (□)	● (■)	● (●)	□ (□)	□ (□)	□ (□)	■ (□)	● (■)	● (●)	■ (□)	● (■)	● (●)
3,0-m-Schnellwechsler (ohne Schnellwechsler)		□ (□)	□ (□)	□ (□)	■ (□)	● (●)	● (●)	□ (□)	□ (□)	□ (□)	■ (■)	● (●)	× (●)	■ (■)	● (●)	● (●)
LC + Planierschild																
2,50-m-Schnellwechsler (ohne Schnellwechsler)		□ (□)	□ (□)	□ (□)	□ (□)	■ (□)	● (■)	□ (□)	□ (□)	□ (□)	□ (□)	■ (■)	● (■)	□ (□)	■ (■)	■ (■)
2,70-m-Schnellwechsler (ohne Schnellwechsler)		□ (□)	□ (□)	□ (□)	□ (□)	■ (■)	● (■)	□ (□)	□ (□)	□ (□)	■ (□)	● (■)	● (●)	□ (□)	● (■)	● (■)
3,0-m-Schnellwechsler (ohne Schnellwechsler)		□ (□)	□ (□)	□ (□)	■ (□)	● (■)	● (●)	□ (□)	□ (□)	□ (□)	■ (□)	● (■)	● (●)	■ (□)	● (■)	● (●)

- = Materialgewicht bis zu 1.200 kg/m³.
- = Materialgewicht bis zu 1.600 kg/m³.
- = Materialgewicht bis zu 2.000 kg/m³.

Diese Empfehlungen sind Richtwerte für normale Betriebsbedingungen.

Wenden Sie sich bezüglich der Auswahl passender Löffel und Anbaugeräte für den jeweiligen Einsatz an Ihren Händler.

ARBEITSBEREICH – LC-MONOAUSLEGER 4,7 M







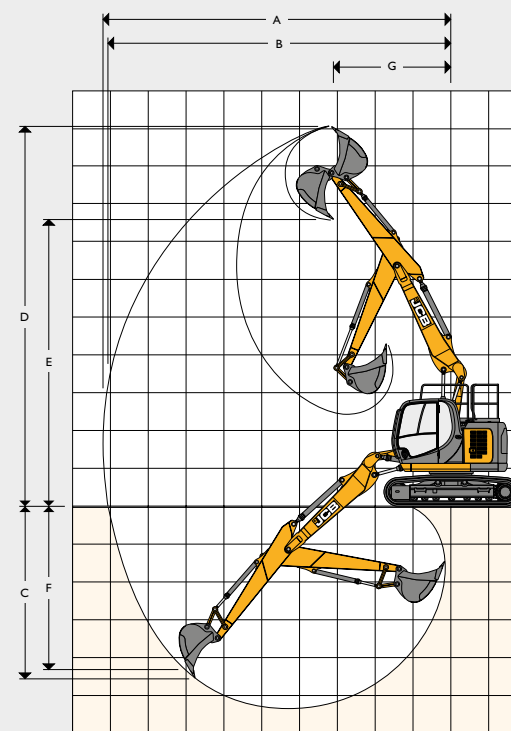
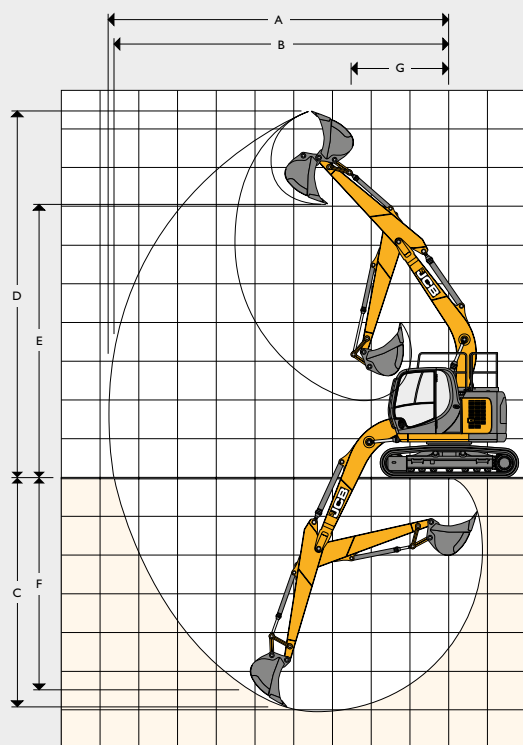







Löffelstiellänge:		2,5 m	2,7 m	3,0 m	
A	Max. Grabreichweite	mm	8.331	8.465	8.787
B	Max. Grabreichweite (am Boden)	mm	8.187	8.324	8.651
C	Max. Grabtiefe	mm	5.557	5.762	6.055
D	Max. Schürfhöhe	mm	9.160	9.275	9.469
E	Max. Schütthöhe	mm	6.692	6.807	7.015
F	Max. vertikale Grabtiefe	mm	4.986	5.073	5.488
G	Mindestschwenkradius	mm	2.175	2.468	2.535
	Löffelrotation	Grad	182	182	182
	Max. Ausbrechkraft Löffelstiel	kNm	66,3	64,8	60,1
	Max. Reißkraft Löffel	kNm	92	92	92

ARBEITSBEREICH – LC-VERSTELLAUSLEGER 5,0 M

Löffelstiellänge:		2,5 m	2,7 m	3,0 m	
A	Max. Grabreichweite	mm	8.742	8.884	9.217
B	Max. Grabreichweite (am Boden)	mm	8.608	8.754	9.090
C	Max. Grabtiefe	mm	4.883	5.183	5.382
D	Max. Schürfhöhe	mm	9.654	9.733	10.030
E	Max. Schütthöhe	mm	7.186	7.289	7.562
F	Max. vertikale Grabtiefe	mm	3.909	4.016	4.336
G	Mindestschwenkradius	mm	2.691	3.090	3.109
	Löffelrotation	Grad	182	182	182
	Max. Ausbrechkraft Löffelstiel	kNm	66,3	64,8	60,1
	Max. Reißkraft Löffel	kNm	92	92	92



HUBKAPAZITÄTEN – LÖFFELSTIELLÄNGE: 2,5-M-, 4,7-M-MONOAUSLEGER, BODENPLATTEN: 500 MM, KEIN LÖFFEL **JZ140 LC-MONOBLOCKAUSLEGER**

Reichweite	2 m		3 m		4 m		5 m		6 m		7 m		Kapazität bei max. Reichweite			
																mm
Lastpunkthöhe	kg	kg	kg	kg	kg	kg	kg	kg	kg	kg	kg	kg	kg	kg	kg	mm
6,0 m					3.450*	3.450*	3.660*	3.180						2.360*	2.360*	5.490
5,0 m					3.670*	3.670*	3.720*	3.160	2.970*	2.320				2.220*	2.190	6.179
4,0 m			4.720*	4.720*	4.280*	4.280*	4.030*	3.090	3.350	2.300				2.160*	1.920	6.648
3,0 m			6.560*	6.560*	5.190*	4.190	4.390*	2.980	3.290	2.240				2.160*	1.760	6.941
2,0 m			8.610*	6.070	6.050*	3.950	4.250	2.850	3.210	2.170	2.520	1.700		2.220*	1.670	7.080
1,0 m			6.750*	5.710	5.820	3.750	4.120	2.730	3.140	2.100	2.490	1.670		2.330*	1.640	7.076
0 m			7.090*	5.550	5.670	3.620	4.030	2.650	3.080	2.050				2.500*	1.670	6.926
- 1,0 m	4.840*	4.840*	9.110*	5.510	5.600	3.560	3.970	2.600	3.050	2.020				2.650	1.770	6.623
- 2,0 m	7.500*	7.500*	9.310	5.530	5.590	3.550	3.960	2.590	3.050	2.030				2.960	1.970	6.141
- 3,0 m	10.940*	10.940*	9.090*	5.600	5.640	3.590	4.000	2.620						3.560	2.360	5.435

HUBKAPAZITÄTEN – LÖFFELSTIELLÄNGE: 2,5-M-, 4,7-M-MONOAUSLEGER, BODENPLATTEN: 500 MM, KEIN LÖFFEL, PLANIERSCHILD **JZ140 LC-MONOBLOCKAUSLEGER**

Reichweite	2 m		3 m		4 m		5 m		6 m		7 m		Kapazität bei max. Reichweite			
																mm
Lastpunkthöhe	kg	kg	kg	kg	kg	kg	kg	kg	kg	kg	kg	kg	kg	kg	kg	mm
6,0 m					3.450*	3.450*	3.660*	3.330						2.360*	2.360*	5.490
5,0 m					3.670*	3.670*	3.720*	3.320	2.970*	2.440				2.220*	2.220*	6.179
4,0 m			4.720*	4.720*	4.280*	4.280*	4.030*	3.250	3.370	2.420				2.160*	2.030	6.648
3,0 m			6.560*	6.560*	5.190*	4.400	4.420	3.140	3.310	2.370				2.160*	1.860	6.941
2,0 m			8.610*	6.390	6.090*	4.160	4.280	3.010	3.240	2.300	2.550	1.810		2.220*	1.770	7.080
1,0 m			6.750*	6.030	5.860	3.960	4.150	2.890	3.160	2.230	2.510	1.770		2.330*	1.750	7.076
0 m			7.090*	5.870	5.710	3.830	4.060	2.800	3.100	2.180				2.520	1.780	6.926
- 1,0 m	4.840*	4.840*	9.110*	5.820	5.640	3.770	4.000	2.750	3.070	2.150				2.680	1.880	6.623
- 2,0 m	7.500*	7.500*	9.380	5.840	5.630	3.760	3.990	2.740	3.080	2.150				2.990	2.090	6.141
- 3,0 m	10.940*	10.940*	9.090*	5.920	5.670	3.800	4.030	2.780						3.590	2.500	5.435

HUBKAPAZITÄTEN – LÖFFELSTIELLÄNGE: 2,7-M-, 4,7-M-MONOAUSLEGER, BODENPLATTEN: 500 MM, KEIN LÖFFEL **JZ140 LC-MONOBLOCKAUSLEGER**

Reichweite	2 m		3 m		4 m		5 m		6 m		7 m		Kapazität bei max. Reichweite			
																mm
Lastpunkthöhe	kg	kg	kg	kg	kg	kg	kg	kg	kg	kg	kg	kg	kg	kg	kg	mm
6,0 m					3.200*	3.200*	3.480*	3.210						2.470*	2.470*	5.720
5,0 m					3.430*	3.430*	3.530*	3.190	3.390	2.340				2.340*	2.080	6.384
4,0 m					4.030*	4.030*	3.840*	3.110	3.360	2.310				2.290*	1.830	6.839
3,0 m			6.110*	6.110*	4.940*	4.220	4.350*	2.990	3.300	2.250	2.560	1.740		2.290*	1.680	7.124
2,0 m			8.180*	6.140	5.980*	3.980	4.260	2.860	3.210	2.170	2.520	1.700		2.350*	1.600	7.260
1,0 m			7.560*	5.730	5.840	3.760	4.120	2.730	3.130	2.100	2.480	1.660		2.350	1.570	7.255
0 m			7.290*	5.530	5.670	3.610	4.020	2.640	3.070	2.040	2.450	1.630		2.400	1.600	7.110
- 1,0 m	4.700*	4.700*	8.960*	5.460	5.580	3.530	3.950	2.580	3.030	2.000				2.530	1.680	6.814
- 2,0 m	7.130*	7.130*	9.250	5.470	5.550	3.510	3.930	2.560	3.020	2.000				2.800	1.860	6.348
- 3,0 m	10.290*	10.290*	9.310*	5.540	5.590	3.550	3.960	2.590						3.330	2.200	5.667

 Hubkapazität in Längsrichtung

 Hubkapazität im gesamten Schwenkbereich

- Hinweise:**
1. Für die Hubkapazität mit Löffel muss das Gesamtgewicht des Löffels bzw. des Löffels und des Schnellwechslers von den vorstehenden Werten abgezogen werden.
 2. Die Hubkapazitäten basieren auf ISO 10567, d. h.: 75 % der Kipplast oder 87 % der Hydraulikhubkapazität – es gilt der jeweils kleinere Wert. Mit * markierte Hubkapazitäten basieren auf der Hydraulikhubkapazität.
 3. Die angegebenen Hubkapazitäten setzen festen, ebenen Grund voraus.
 4. Unterschiedliche Länder haben ggf. andere gesetzliche Bestimmungen. Fragen Sie bitte Ihren Händler.

HUBKAPAZITÄTEN – LÖFFELSTIELLÄNGE: 2,7-M-, 4,7-M-MONOAUSLEGER, BODENPLATTEN: 500 MM, KEIN LÖFFEL, PLANIERSCHILD **JZ140 LC-MONOBLOCKAUSLEGER**

Reichweite	2 m		3 m		4 m		5 m		6 m		7 m		Kapazität bei max. Reichweite		
															
Lastpunkthöhe	kg	kg	kg	kg	kg	kg	kg	kg	kg	kg	kg	kg	kg	kg	mm
6,0 m					3.200*	3.200*	3.480*	3.370					2.470*	2.470*	5.720
5,0 m					3.430*	3.430*	3.530*	3.350	3.420	2.470			2.340*	2.200	6.384
4,0 m					4.030*	4.030*	3.840*	3.270	3.390	2.440			2.290*	1.940	6.839
3,0 m			6.110*	6.110*	4.940*	4.440	4.350*	3.150	3.320	2.370	2.590	1.840	2.290*	1.790	7.124
2,0 m			8.180*	6.460	5.980*	4.190	4.290	3.020	3.240	2.300	2.550	1.810	2.350*	1.700	7.260
1,0 m			7.560*	6.050	5.870	3.970	4.150	2.890	3.160	2.230	2.510	1.770	2.370	1.670	7.255
0 m			7.290*	5.850	5.700	3.820	4.050	2.790	3.100	2.170	2.470	1.740	2.420	1.700	7.110
- 1,0 m	4.700*	4.700*	8.960*	5.780	5.610	3.740	3.980	2.740	3.060	2.130			2.560	1.790	6.814
- 2,0 m	7.130*	7.130*	9.310	5.790	5.590	3.720	3.960	2.720	3.050	2.120			2.830	1.980	6.348
- 3,0 m	10.290*	10.290*	9.310*	5.860	5.630	3.760	3.990	2.740					3.350	2.340	5.667

HUBKAPAZITÄTEN – LÖFFELSTIELLÄNGE: 3,0-M-, 4,7-M-MONOAUSLEGER, BODENPLATTEN: 500 MM, KEIN LÖFFEL **JZ140 LC-MONOBLOCKAUSLEGER**

Reichweite	2 m		3 m		4 m		5 m		6 m		7 m		Kapazität bei max. Reichweite		
															
Lastpunkthöhe	kg	kg	kg	kg	kg	kg	kg	kg	kg	kg	kg	kg	kg	kg	mm
6,0 m							3.150*	3.150*	2.380*	2.350			2.160*	2.160*	6.070
5,0 m							3.230*	3.220	3.360*	2.370			2.050*	1.930	6.699
4,0 m					3.650*	3.650*	3.570*	3.140	3.380	2.330	2.490*	1.770	2.010*	1.710	7.133
3,0 m			5.440*	5.440*	4.560*	4.280	4.090*	3.020	3.310	2.260	2.570	1.750	2.020*	1.580	7.407
2,0 m			7.540*	6.270	5.630*	4.020	4.290	2.880	3.220	2.180	2.530	1.700	2.070*	1.500	7.538
1,0 m			9.270*	5.800	5.870	3.790	4.140	2.740	3.140	2.100	2.480	1.660	2.170*	1.470	7.533
0 m			7.810*	5.540	5.680	3.620	4.020	2.630	3.060	2.030	2.440	1.620	2.250	1.490	7.393
- 1,0 m	4.620*	4.620*	8.850*	5.440	5.560	3.520	3.940	2.560	3.010	1.980	2.420	1.600	2.360	1.570	7.110
- 2,0 m	6.660*	6.660*	9.200	5.420	5.520	3.480	3.900	2.530	2.990	1.970			2.590	1.710	6.664
- 3,0 m	9.310*	9.310*	9.260	5.470	5.540	3.500	3.920	2.540	3.030	2.000			3.010	1.990	6.020

HUBKAPAZITÄTEN – LÖFFELSTIELLÄNGE: 3,0-M-, 4,7-M-MONOAUSLEGER, BODENPLATTEN: 500 MM, KEIN LÖFFEL, PLANIERSCHILD **JZ140 LC-MONOBLOCKAUSLEGER**

Reichweite	2 m		3 m		4 m		5 m		6 m		7 m		Kapazität bei max. Reichweite		
															
Lastpunkthöhe	kg	kg	kg	kg	kg	kg	kg	kg	kg	kg	kg	kg	kg	kg	mm
6,0 m							3.150*	3.150*	2.380*	2.380*			2.160*	2.160*	6.070
5,0 m							3.230*	3.230*	3.360*	2.490			2.050*	2.040	6.699
4,0 m					3.650*	3.650*	3.570*	3.300	3.410	2.450	2.490*	1.880	2.010*	1.810	7.133
3,0 m			5.440*	5.440*	4.560*	4.490	4.090*	3.180	3.340	2.390	2.600	1.850	2.020*	1.670	7.407
2,0 m			7.540*	6.590	5.630*	4.230	4.320	3.040	3.250	2.310	2.550	1.810	2.070*	1.600	7.538
1,0 m			9.270*	6.120	5.910	4.000	4.170	2.900	3.160	2.220	2.500	1.760	2.170*	1.570	7.533
0 m			7.810*	5.860	5.710	3.830	4.050	2.790	3.090	2.160	2.460	1.720	2.270	1.590	7.393
- 1,0 m	4.620*	4.620*	8.850*	5.760	5.600	3.730	3.970	2.720	3.040	2.110	2.440	1.700	2.390	1.670	7.110
- 2,0 m	6.660*	6.660*	9.260	5.740	5.560	3.690	3.930	2.690	3.020	2.090			2.620	1.820	6.664
- 3,0 m	9.310*	9.310*	9.320	5.790	5.580	3.710	3.950	2.700	3.050	2.130			3.040	2.120	6.020



Hubkapazität in Längsrichtung



Hubkapazität im gesamten Schwenkbereich

Hinweise:

1. Für die Hubkapazität mit Löffel muss das Gesamtgewicht des Löffels bzw. des Löffels und des Schnellwechslers von den vorstehenden Werten abgezogen werden.
2. Die Hubkapazitäten basieren auf ISO 10567, d. h.: 75 % der Kipplast oder 87 % der Hydraulikhubkapazität – es gilt der jeweils kleinere Wert. Mit * markierte Hubkapazitäten basieren auf der Hydraulikhubkapazität.
3. Die angegebenen Hubkapazitäten setzen festen, ebenen Grund voraus.
4. Unterschiedliche Länder haben ggf. andere gesetzliche Bestimmungen. Fragen Sie bitte Ihren Händler.

HUBKAPAZITÄTEN – LÖFFELSTIELLÄNGE: 2,5-M-, 5,0-M-VERSTELLAUSLEGER, BODENPLATTEN: 500 MM, KEIN LÖFFEL													JZ140 LC-VERSTELLAUSLEGER			
Reichweite	2 m		3 m		4 m		5 m		6 m		7 m		Kapazität bei max. Reichweite			
Lastpunkthöhe	kg	kg	kg	kg	kg	kg	kg	kg	kg	kg	kg	kg	kg	kg	kg	mm
6,0 m					3.490*	3.490*	3.550*	3.210	2.530*	2.280			2.430*	2.270	6.014	
5,0 m					3.800*	3.800*	3.660*	3.170	3.400	2.310			2.260*	1.890	6.649	
4,0 m			5.080*	5.080*	4.440*	4.380	4.000*	3.060	3.350	2.270	2.560	1.710	2.180*	1.670	7.086	
3,0 m					5.320*	4.100	4.360	2.920	3.260	2.190	2.540	1.690	2.160*	1.530	7.361	
2,0 m					5.940	3.810	4.190	2.760	3.170	2.100	2.490	1.650	2.170*	1.460	7.493	
1,0 m					5.680	3.580	4.040	2.620	3.080	2.020	2.440	1.600	2.200	1.440	7.488	
0 m					5.520	3.440	3.930	2.520	3.010	1.960	2.410	1.570	2.250	1.460	7.347	
- 1,0 m			6.010*	5.260	5.460	3.380	3.870	2.470	2.970	1.920	2.400	1.560	2.370	1.550	7.062	
- 2,0 m	5.440*	5.440*	9.000*	5.300	5.460	3.380	3.860	2.460	2.970	1.920			2.620	1.710	6.613	
- 3,0 m			8.640*	5.400	5.520	3.440	3.900	2.500					3.070	2.010	5.964	

HUBKAPAZITÄTEN – LÖFFELSTIELLÄNGE: 2,5-M-, 5,0-M-VERSTELLAUSLEGER, BODENPLATTEN: 500 MM, KEIN LÖFFEL, PLANIERSCHILD													JZ140 LC-VERSTELLAUSLEGER			
Reichweite	2 m		3 m		4 m		5 m		6 m		7 m		Kapazität bei max. Reichweite			
Lastpunkthöhe	kg	kg	kg	kg	kg	kg	kg	kg	kg	kg	kg	kg	kg	kg	kg	mm
6,0 m					3.490*	3.490*	3.550*	3.370	2.530*	2.400			2.430*	2.390	6.014	
5,0 m					3.800*	3.800*	3.660*	3.320	3.420	2.440			2.260*	2.000	6.649	
4,0 m			5.080*	5.080*	4.440*	4.440*	4.000*	3.220	3.370	2.390	2.580	1.820	2.180*	1.770	7.086	
3,0 m					5.320*	4.310	4.390	3.070	3.290	2.320	2.560	1.800	2.160*	1.630	7.361	
2,0 m					5.980	4.020	4.220	2.920	3.190	2.230	2.510	1.750	2.170*	1.560	7.493	
1,0 m					5.720	3.790	4.070	2.780	3.100	2.140	2.460	1.710	2.220	1.540	7.488	
0 m					5.560	3.650	3.960	2.680	3.030	2.080	2.430	1.670	2.270	1.560	7.347	
- 1,0 m			6.010*	5.580	5.500	3.590	3.900	2.630	3.000	2.050	2.420	1.670	2.390	1.650	7.062	
- 2,0 m	5.440*	5.440*	9.000*	5.620	5.500	3.590	3.890	2.620	3.000	2.050			2.640	1.820	6.613	
- 3,0 m			8.640*	5.720	5.560	3.650	3.930	2.660					3.100	2.130	5.964	

HUBKAPAZITÄTEN – LÖFFELSTIELLÄNGE: 2,7-M-, 5,0-M-VERSTELLAUSLEGER, BODENPLATTEN: 500 MM, KEIN LÖFFEL													JZ140 LC-VERSTELLAUSLEGER			
Reichweite	2 m		3 m		4 m		5 m		6 m		7 m		Kapazität bei max. Reichweite			
Lastpunkthöhe	kg	kg	kg	kg	kg	kg	kg	kg	kg	kg	kg	kg	kg	kg	kg	mm
6,0 m							3.370*	3.240	3.410*	2.330			2.540*	2.130	6.248	
5,0 m					3.580*	3.580*	3.500*	3.200	3.240	2.340			2.390*	1.800	6.860	
4,0 m			4.130*	4.130*	4.210*	4.210*	3.840*	3.090	3.360	2.280	2.580	1.730	2.300*	1.590	7.285	
3,0 m					5.090*	4.140	4.340*	2.940	3.270	2.200	2.540	1.700	2.220	1.470	7.553	
2,0 m					5.980	3.840	4.210	2.770	3.170	2.110	2.490	1.650	2.140	1.400	7.681	
1,0 m					5.690	3.590	4.040	2.620	3.070	2.020	2.440	1.600	2.110	1.380	7.677	
0 m					5.520	3.430	3.920	2.510	3.000	1.950	2.390	1.560	2.150	1.400	7.539	
- 1,0 m			5.880*	5.200	5.430	3.360	3.850	2.450	2.950	1.900	2.380	1.540	2.260	1.470	7.262	
- 2,0 m	5.140*	5.140*	8.580*	5.240	5.420	3.340	3.830	2.430	2.940	1.900			2.480	1.610	6.826	
- 3,0 m			8.860*	5.330	5.470	3.390	3.870	2.460	2.990	1.940			2.880	1.880	6.199	



Hubkapazität in Längsrichtung

Hinweise:

1. Für die Hubkapazität mit Löffel muss das Gesamtgewicht des Löffels bzw. des Löffels und des Schnellwechslers von den vorstehenden Werten abgezogen werden.
2. Die Hubkapazitäten basieren auf ISO 10567, d. h.: 75 % der Kipplast oder 87 % der Hydraulikhubkapazität – es gilt der jeweils kleinere Wert. Mit * markierte Hubkapazitäten basieren auf der Hydraulikhubkapazität.
3. Die angegebenen Hubkapazitäten setzen festen, ebenen Grund voraus.
4. Unterschiedliche Länder haben ggf. andere gesetzliche Bestimmungen. Fragen Sie bitte Ihren Händler.

Hubkapazität im gesamten Schwenkbereich

HUBKAPAZITÄTEN – LÖFFELSTIELLÄNGE: 2,7-M-, 5,0-M-VERSTELLAUSLEGER, BODENPLATTEN: 500 MM, KEIN LÖFFEL, PLANIERSCHILD **JZ140 LC-VERSTELLAUSLEGER**

Reichweite	2 m		3 m		4 m		5 m		6 m		7 m		Kapazität bei max. Reichweite			
																mm
Lastpunkthöhe	kg	kg	kg	kg	kg	kg	kg	kg	kg	kg	kg	kg	kg	kg	kg	mm
6,0 m							3.370*	3.370*	3.410*	2.450			2.540*	2.250	6.248	
5,0 m					3.580*	3.580*	3.500*	3.350	3.450	2.460			2.390*	1.900	6.860	
4,0 m			4.130*	4.130*	4.210*	4.210*	3.840*	3.240	3.390	2.410	2.600	1.840	2.300*	1.690	7.285	
3,0 m					5.090*	4.350	4.340*	3.090	3.300	2.330	2.570	1.800	2.240	1.560	7.553	
2,0 m					6.020	4.050	4.230	2.930	3.200	2.230	2.510	1.750	2.160	1.490	7.681	
1,0 m					5.730	3.800	4.070	2.780	3.100	2.140	2.460	1.700	2.130	1.470	7.677	
0 m					5.550	3.640	3.950	2.670	3.020	2.070	2.420	1.660	2.170	1.490	7.539	
- 1,0 m			5.880*	5.520	5.470	3.570	3.880	2.610	2.980	2.030	2.400	1.640	2.290	1.570	7.262	
- 2,0 m	5.140*	5.140*	8.580*	5.550	5.460	3.560	3.860	2.590	2.970	2.020			2.500	1.720	6.826	
- 3,0 m			8.860*	5.640	5.510	3.600	3.900	2.620	3.020	2.070			2.910	2.000	6.199	

HUBKAPAZITÄTEN – LÖFFELSTIELLÄNGE: 3,0-M-, 5,0-M-VERSTELLAUSLEGER, BODENPLATTEN: 500 MM, KEIN LÖFFEL **JZ140 LC-VERSTELLAUSLEGER**

Reichweite	2 m		3 m		4 m		5 m		6 m		7 m		Kapazität bei max. Reichweite			
																mm
Lastpunkthöhe	kg	kg	kg	kg	kg	kg	kg	kg	kg	kg	kg	kg	kg	kg	kg	mm
6,0 m							3.100*	3.100*	3.240*	2.380			2.210*	1.950	6.599	
5,0 m							3.250*	3.240	3.250*	2.370	2.620	1.760	2.090*	1.660	7.182	
4,0 m					3.760*	3.760*	3.600*	3.130	3.390	2.310	2.600	1.750	2.020*	1.480	7.588	
3,0 m					4.750*	4.210	4.100*	2.970	3.330	2.220	2.560	1.710	2.010*	1.370	7.845	
2,0 m					5.740*	3.900	4.240	2.800	3.190	2.120	2.500	1.650	2.010	1.310	7.969	
1,0 m					5.740	3.620	4.060	2.640	3.080	2.020	2.430	1.590	1.990	1.290	7.965	
0 m					5.530	3.440	3.920	2.510	2.990	1.940	2.380	1.540	2.020	1.300	7.833	
- 1,0 m			5.870*	5.170	5.410	3.340	3.840	2.430	2.940	1.880	2.350	1.520	2.110	1.360	7.566	
- 2,0 m	4.850*	4.850*	8.080*	5.170	5.380	3.310	3.800	2.400	2.910	1.870	2.360	1.520	2.300	1.490	7.149	
- 3,0 m	7.270*	7.270*	9.070	5.240	5.410	3.340	3.820	2.420	2.940	1.890			2.630	1.700	6.553	

HUBKAPAZITÄTEN – LÖFFELSTIELLÄNGE: 3,0-M-, 5,0-M-VERSTELLAUSLEGER, BODENPLATTEN: 500 MM, KEIN LÖFFEL, PLANIERSCHILD **JZ140 LC-VERSTELLAUSLEGER**

Reichweite	2 m		3 m		4 m		5 m		6 m		7 m		Kapazität bei max. Reichweite			
																mm
Lastpunkthöhe	kg	kg	kg	kg	kg	kg	kg	kg	kg	kg	kg	kg	kg	kg	kg	mm
6,0 m							3.100*	3.100*	3.240*	2.500			2.210*	2.060	6.599	
5,0 m							3.250*	3.250*	3.250*	2.490	2.640	1.870	2.090*	1.760	7.182	
4,0 m					3.760*	3.760*	3.600*	3.280	3.420	2.430	2.630	1.860	2.020*	1.580	7.588	
3,0 m					4.750*	4.430	4.100*	3.130	3.320	2.340	2.580	1.810	2.010*	1.460	7.845	
2,0 m					5.740*	4.110	4.260	2.950	3.210	2.240	2.520	1.750	2.030*	1.400	7.969	
1,0 m					5.780	3.830	4.090	2.790	3.100	2.140	2.460	1.700	2.010	1.380	7.965	
0 m					5.560	3.650	3.950	2.670	3.020	2.060	2.410	1.650	2.040	1.390	7.833	
- 1,0 m			5.870*	5.490	5.450	3.550	3.870	2.590	2.960	2.010	2.370	1.620	2.140	1.460	7.566	
- 2,0 m	4.850*	4.850*	8.080*	5.490	5.420	3.520	3.830	2.560	2.940	1.990	2.380	1.620	2.320	1.590	7.149	
- 3,0 m	7.270*	7.270*	9.130	5.560	5.450	3.550	3.850	2.580	2.970	2.010			2.930	1.820	6.553	



Hubkapazität in Längsrichtung



Hubkapazität im gesamten Schwenkbereich

Hinweise:

1. Für die Hubkapazität mit Löffel muss das Gesamtgewicht des Löffels bzw. des Löffels und des Schnellwechslers von den vorstehenden Werten abgezogen werden.
2. Die Hubkapazitäten basieren auf ISO 10567, d. h.: 75 % der Kipplast oder 87 % der Hydraulikhubkapazität – es gilt der jeweils kleinere Wert. Mit * markierte Hubkapazitäten basieren auf der Hydraulikhubkapazität.
3. Die angegebenen Hubkapazitäten setzen festen, ebenen Grund voraus.
4. Unterschiedliche Länder haben ggf. andere gesetzliche Bestimmungen. Fragen Sie bitte Ihren Händler.





EIN UNTERNEHMEN, ÜBER 300 MODELLE

Der JCB-Händler in Ihrer Nähe

Raupenbagger JZ140 LC

Brutto-Motorleistung: 81 kW (109 PS) Löffelinhalt: 0,35–0,89 m³ Betriebsgewicht: 15.084–16.826 kg

JCB TracTechnik GmbH
 Gastgebgsasse 27
 1230 Wien
www.jcb-tractechnik.at

©2021 JCB Sales. Alle Rechte vorbehalten. Dieses Dokument darf ohne vorherige Genehmigung durch JCB Sales weder vollständig noch teilweise vervielfältigt, in einem Erfassungssystem gespeichert, oder in jedweder Form sowie Methode elektronisch, mechanisch, fototechnisch oder sonst wie übermittelt werden. Sämtliche Angaben in diesem Dokument hinsichtlich Betriebsgewicht, Größe, Arbeitsgeschwindigkeit sowie sonstiger Leistungsdaten dienen nur zur Veranschaulichung und können je nach genauer Maschinenausrüstung abweichen. Sie sollten daher nicht als Nachweis zur Eignung der Maschine für einen bestimmten Einsatzzweck dienen. Lassen Sie sich unbedingt von Ihrem JCB Händler beraten. JCB behält sich das Recht vor, ohne vorherige Benachrichtigung technische Änderungen vorzunehmen. Die im Werbematerial enthaltenen Abbildungen und Angaben gelten nur als Richtlinie und können in gewissen Märkten vom Lieferumfang abweichen. Alle Bilder sind zum Zeitpunkt der Drucklegung gültig. Das JCB Logo ist eine eingetragene Marke von J. C. Bamford Excavators Ltd.

29723 de-DE 01/22 Ausgabe I (T4F)

